

Wheelguides (bolt down) guide HGVs safely in to position

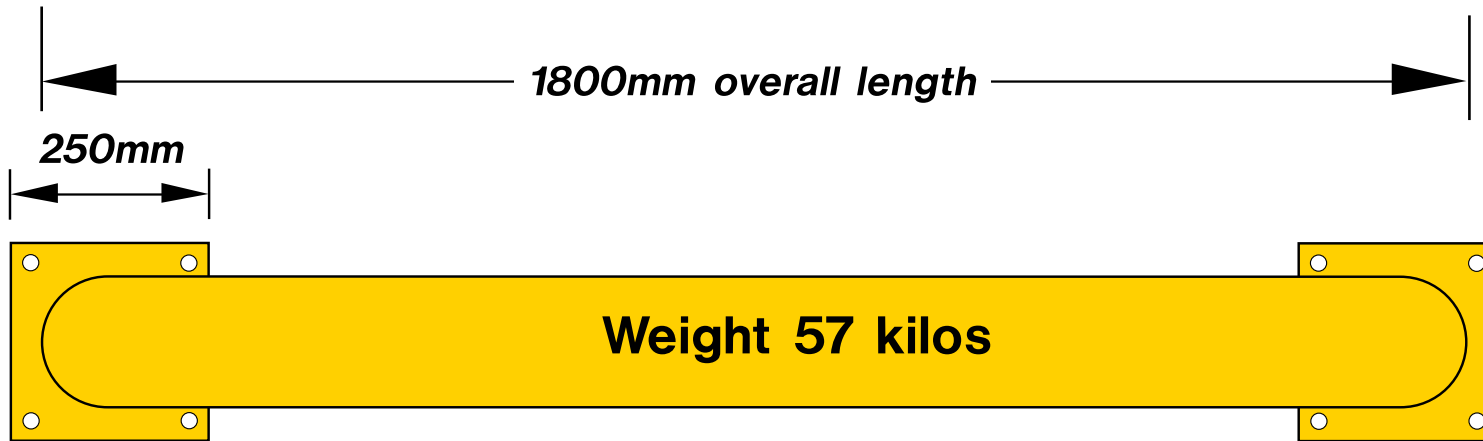

Hazard

Brunel House

55/57 Bristol Road
Edgbaston
Birmingham
B5 7TU

Tel: 0121 446 4433

Fax: 0121 446 4230

Website: www.hazard.co.uk

email: sales@hazard.co.uk

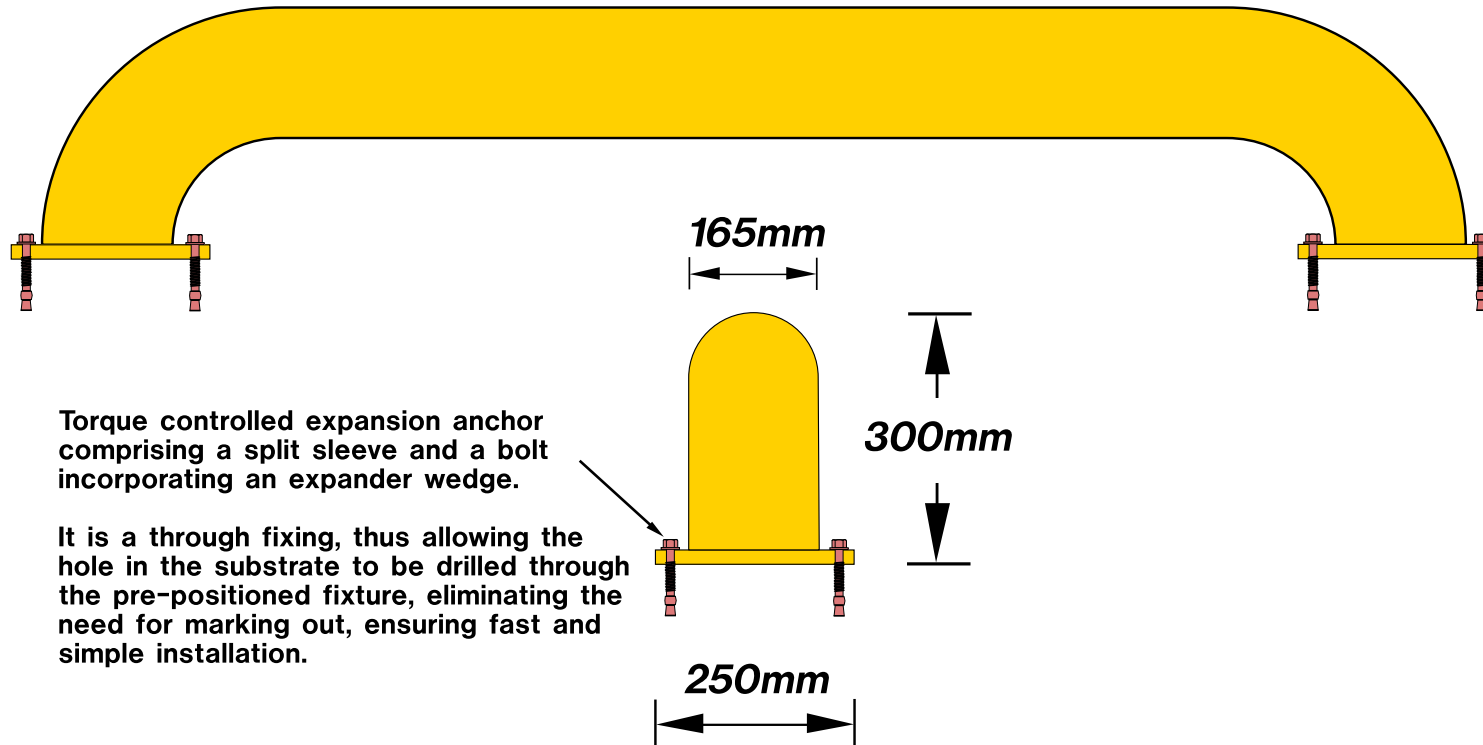

Wheelguides Specification

Material Specifications:

The steel materials used for this assembly are to the highest standard of S275JR (BS EN 10025:1993), therefore ensuring the longevity and durability of the product.

Paint Specification

Main body is painted in a exterior grade high quality powder coat full gloss finish painted bright Yellow for high visibility.

Construction Specification:

The assembly is laser cut for accuracy with all joints dove-tailed together for strength and then welded.

Wheelguides (foundation) guide HGVs safely in to position



Hazard



Hazard
Brunel House
55/57 Bristol Road
Edgbaston
Birmingham
B5 7TU

Tel: 0121 446 4433
Fax: 0121 446 4230
Website: www.hazard.co.uk
email: sales@hazard.co.uk

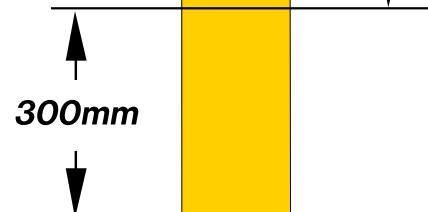
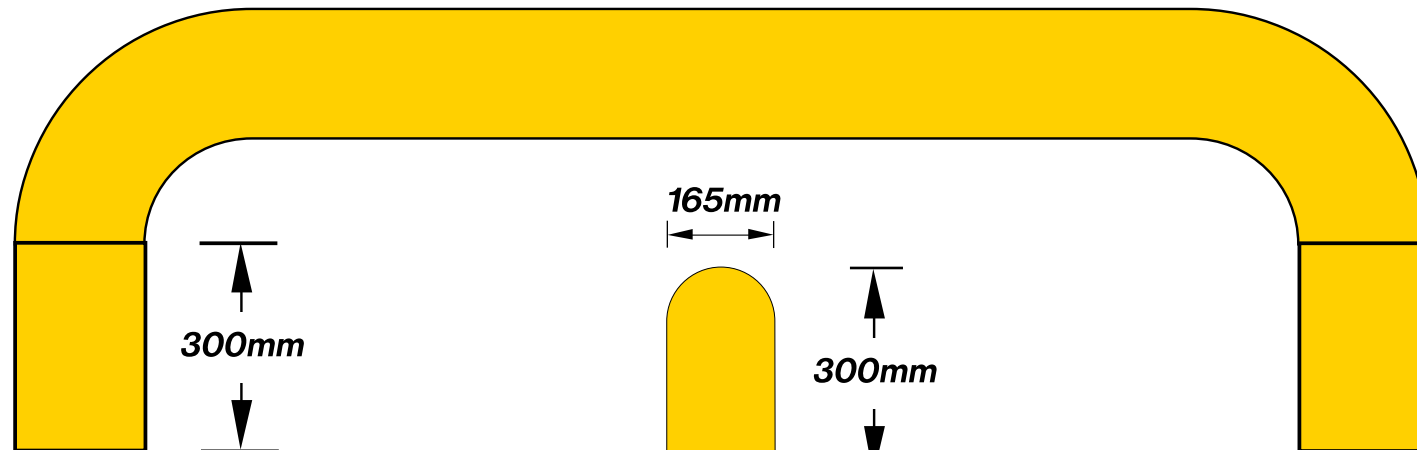

Planting depth
Concrete
foundation
to engineers
specification

Wheelguides Specification

Material Specifications:

The steel materials used for this assembly are to the highest standard of S275JR (BS EN 10025:1993), therefore ensuring the longevity and durability of the product.

Paint Specification

Main body is painted in a exterior grade high quality powder coat full gloss finish painted bright Yellow for high visibility.

Construction Specification:

The assembly is laser cut for accuracy with all joints dove-tailed together for strength and then welded.