

# HR2 Cable protectors

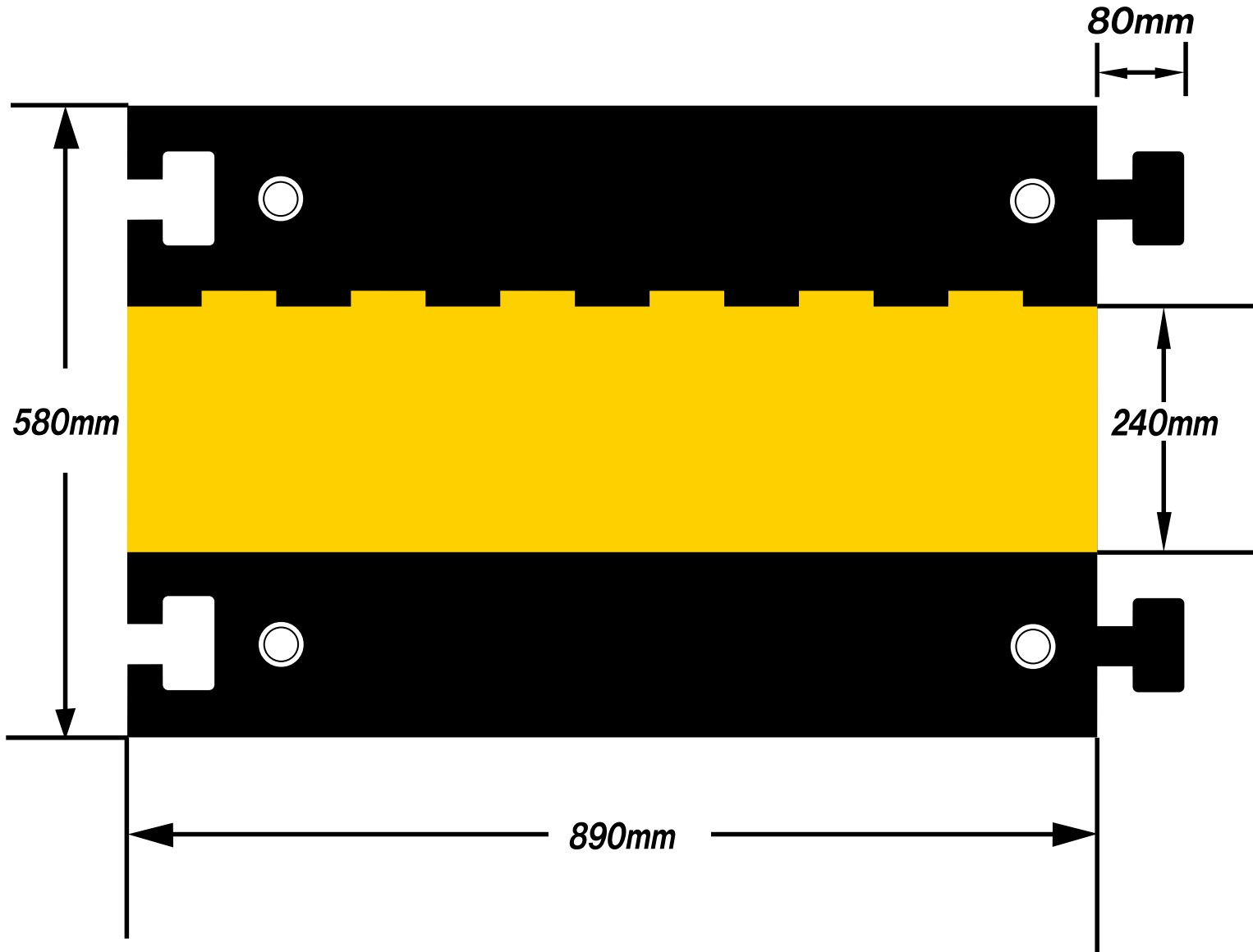

**Hazard**  
**Brunel House**  
 55/57 Bristol Road  
 Edgbaston  
 Birmingham  
 B5 7TU

Tel: 0121 446 4433  
 Fax: 0121 446 4230  
 Website: [www.hazard.co.uk](http://www.hazard.co.uk)  
 email: [sales@hazard.co.uk](mailto:sales@hazard.co.uk)

## EPDM Blend Rubber Specification

Test	Test Method	Limits
Tensile	BS903 A2	10.5 Mpa
Elongation	BS903 A2	300 % minimum
Hardness	BS903 A26	65 - 75 IRHD
Heat Ageing 7 days at 70 degrees C		
a) Tensile retention		90% minimum
b) Elongation retention		80% minimum
c) Hardness change		+7 IRHD
Compression set	BS903 A6A	30% maximum
22 hours at 70 degrees C		
Tear resistance	BS903 A3 method c	40 N/mm minimum
Material	EPDM/SBR/Natural Rubber +/- 10% unless Otherwise stated	

EPDM/SBR/Natural rubber blend.  
 Filled with carbon black.  
 The material has resistance to ultra violet light, ageing, sea water, fatigue and abrasion.  
 The rubber is of uniform quality and free from foreign substances.

# HR2 Cable protectors

**Hazard**  
**Brunel House**  
55/57 Bristol Road  
Edgbaston  
Birmingham  
B5 7TU

Tel: 0121 446 4433  
Fax: 0121 446 4230  
Website: [www.hazard.co.uk](http://www.hazard.co.uk)  
email: [sales@hazard.co.uk](mailto:sales@hazard.co.uk)

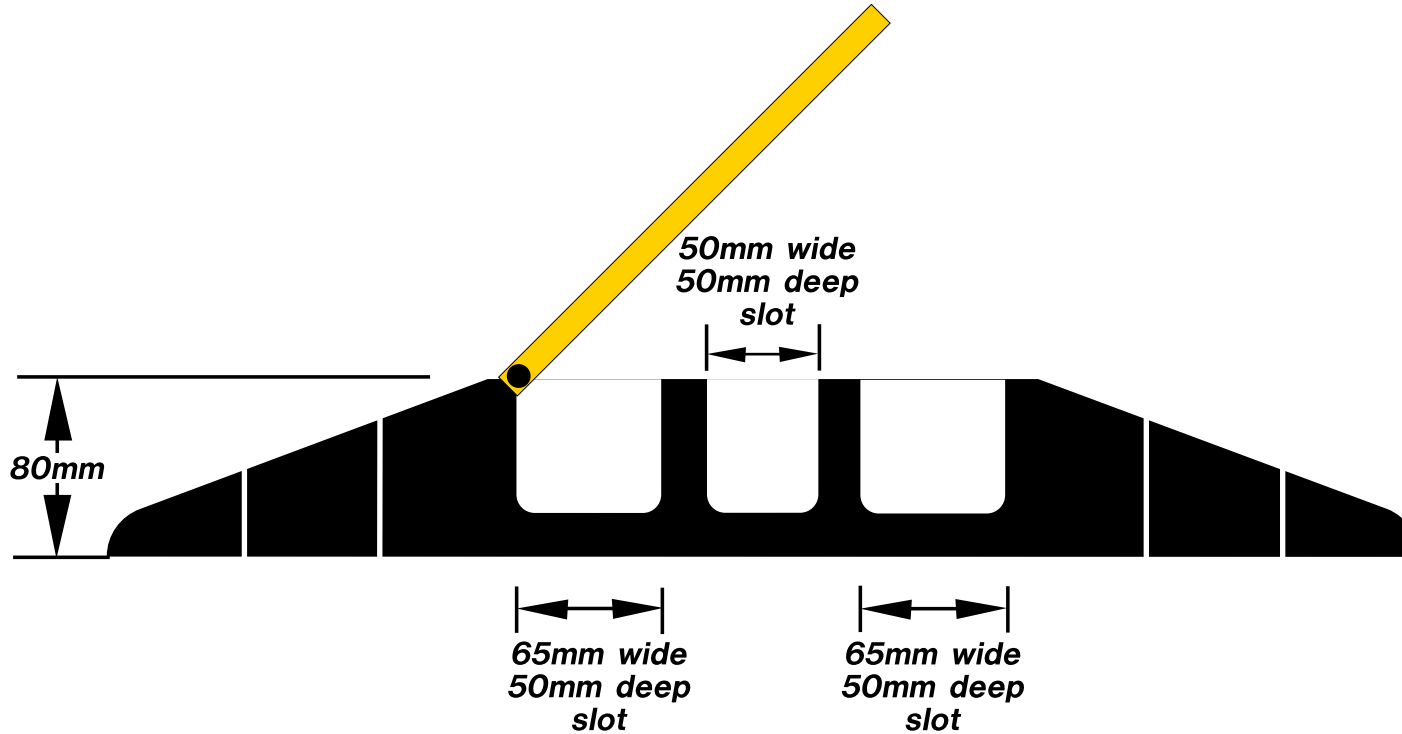

## EPDM Blend Rubber Specification

Test	Test Method	Limits
Tensile	BS903 A2	10.5 Mpa
Elongation	BS903 A2	300 % minimum
Hardness	BS903 A26	65 - 75 IRHD
Heat Ageing	7 days at 70 degrees C	
a)	Tensile retention	90% minimum
b)	Elongation retention	80% minimum
c)	Hardness change	+7 IRHD
Compression set	BS903 A6A	30% maximum
	22 hours at 70 degrees C	
Tear resistance	BS903 A3 method c	40 N/mm minimum
Material	EPDM/SBR/Natural Rubber +/- 10% unless Otherwise stated	

EPDM/SBR/Natural rubber blend.  
Filled with carbon black.  
The material has resistance to ultra violet light, ageing, sea water, fatigue and abrasion.  
The rubber is of uniform quality and free from foreign substances.